



Applies To: **See VEHICLES AFFECTED**

**April 1, 2004**

## Safety Recall: Combination Light Switch

(Supersedes 04-015, dated March 26, 2004)

### BACKGROUND

A terminal in the headlight wire harness connector can overheat and may cause the low-beam headlights to fail without warning. Although the high-beam position remains operational, an unexpected loss of low beams could result in a crash.

### VEHICLES AFFECTED

**2001 Civic: ALL**

**2002 Civic:**

2-door

From VIN 1HGEM2...2L000001 thru  
1HGEM2...2L024169

4-door

From VIN 1HGES1...2L000001 thru  
1HGES1...2L024203

From VIN 1HGES2...2L000001 thru  
1HGES2...2L028089

From VIN 2HGES...2H500001 thru  
2HGES...2H530552

From VIN JHMES1...2S000001 thru  
JHMES1...2S004507

From VIN JHMES2...2S000001 thru  
JHMES2...2S002838

Hatchback

From VIN SHHEP3...2U300001 thru  
SHHEP3...2U300222

■ **GX**

From VIN 1HGEN2...2L000001 thru  
1HGEN2...2L000181

**2000-01 Insight: ALL**

### CUSTOMER NOTIFICATION

All owners of affected vehicles will be sent a notification of this recall. An example of the customer notification is at the end of this service bulletin.

Not all vehicles within the VIN ranges are affected by this recall. Before beginning work on a vehicle, verify its eligibility by checking at least one of these items:

- The customer has a notification letter.
- The vehicle is shown on your campaign responsibility report.
- The vehicle is shown as eligible on an iN VIN status inquiry.

In addition to the bulleted verification items, check for a punch mark above the 12th character of the engine compartment VIN. A punch mark in that location means the combination light switch has already been repaired.

Some vehicles affected by this recall may be in your used car inventory. **According to federal law, these vehicles cannot be sold or leased until they are repaired.** To see if a vehicle is affected by this recall, do a VIN status inquiry before selling it.

### CORRECTIVE ACTION

Replace the combination light switch, the RED/WHT wire in the headlight wire harness, and if needed, the 16P headlight wire harness connector.

### PARTS INFORMATION

Combination Light Switch Repair Kit:

(Includes switch, wire harness connector, 250 mm wire with an attached terminal, and wire splice connector)

Civic: P/N 35012-S5A-307, H/C 7743875

Insight: P/N 35012-S3Y-306, H/C 7743883

### TOOL INFORMATION

Terminal Pin Kit C: T/N 07QAZ-003020C, or equivalent (Terminal Pin Kit C contains the wire crimper and the heat gun used for wire splicing.)

Terminal Maintenance Set: T/N 070AZ-S5A0100\*  
[Contains Terminal Remover Set (six small, plastic tools used to remove terminals from the 16P headlight wire harness connector), and Secondary Lock Opener (a miniature, flat-tip screwdriver used to open the secondary locks on the 16P headlight wire harness connector)]

\* This tool is being sent to your dealership along with your initial allocation of combination light switch repair kits.

**NOTE:** If you need additional tools, order them through the parts ordering system.

## WARRANTY CLAIM INFORMATION

OP#	Description	FRT
728103	Replace the combination light switch and the RED/WHT wire in the headlight wire harness	0.7
A	Do the cruise control learn (2001 Civic 2-door thru VIN 1HGEM2...1L016502)	0.3
728104	Replace the combination light switch, the RED/WHT wire in the headlight wire harness, and the 16P wire harness connector	0.8
A	Do the cruise control learn (2001 Civic 2-door thru VIN 1HGEM2...1L016502)	0.3

Failed Part: P/N 35255-S5A-A01  
H/C 6453336

Defect Code: 5CN

Symptom Code: P23

Skill Level: Repair Technician

## REPAIR PROCEDURE

### NOTE:

- SRS components are located in this area. Before you begin, review the SRS component locations, cautions, and procedures in the service manual.
  - Be careful not to damage the dashboard or other interior trim pieces.
  - For information about wire terminal replacement and wire splicing, refer to service bulletin 00-099, *Terminal Replacement Instructions*.
1. Make sure you have the anti-theft code for the radio (if applicable), then write down your customer's radio station presets.
  2. Disconnect the negative cable from the battery.
  3. *On Civics*, remove the driver's dashboard lower cover. For Civic 2/4-door, see the 2001–04 Civic Service Manual, page 20-97. For Civic Hatchback, see the 2002–04 Civic Hatchback Service Manual, page 20-61.

4. Remove the steering column covers (see the 2001–04 Civic Service Manual, page 17-27, step 4; the 2002–04 Civic Hatchback Service Manual, page 17-9, step 4; or the 2000–04 Insight Service Manual, page 17-9, step 5). *On the Insight* steering column, also remove the two front nuts, and loosen the two rear nuts.

*Insight is shown*

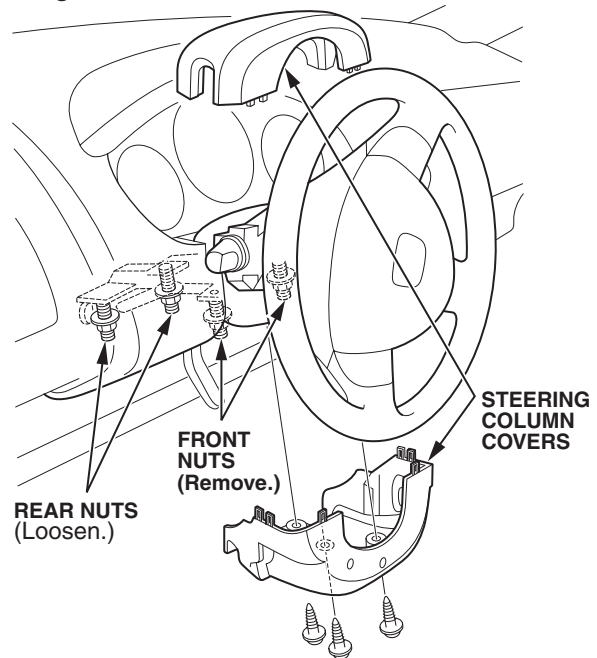

5. *On Civics*, disconnect the 16P connector from the combination light switch and the 5P connector from the cable reel. *On Civic Hatchbacks*, also disconnect the 14P connector from the wiper switch. Then carefully pull the wire harness to the right of the steering column. *On Insights*, disconnect the 16P connector from the combination light switch.

*Civic is shown*

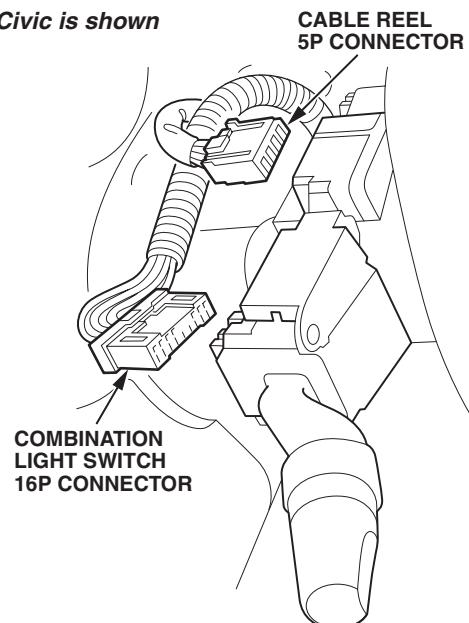

6. Turn the ignition switch to the ACCESSORY (I) position, then turn the steering wheel to the right.
7. Remove the two screws from the combination light switch.

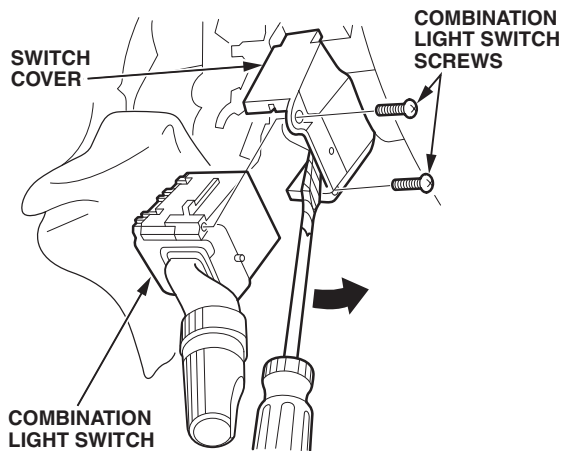

8. Using a flat-tip screwdriver wrapped with electrical tape, slightly lift the switch cover, then remove the switch, and discard it.
9. Remove the tape or corrugated tubing/foam from the 16P connector wire harness to expose about 200 mm of wire. Discard the tape, but retain the tubing/foam.

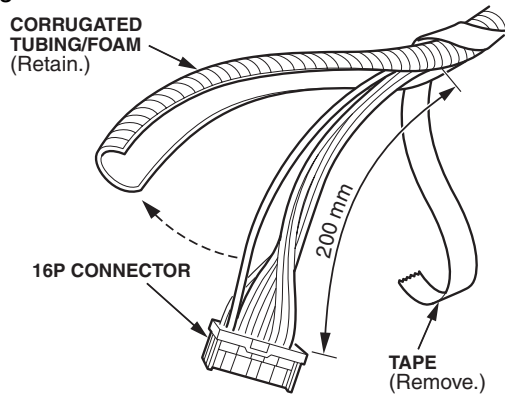

10. Locate the RED/WHT wire in the 16P connector. Then measure 150 mm from the end of the connector, and cut the RED/WHT wire there.

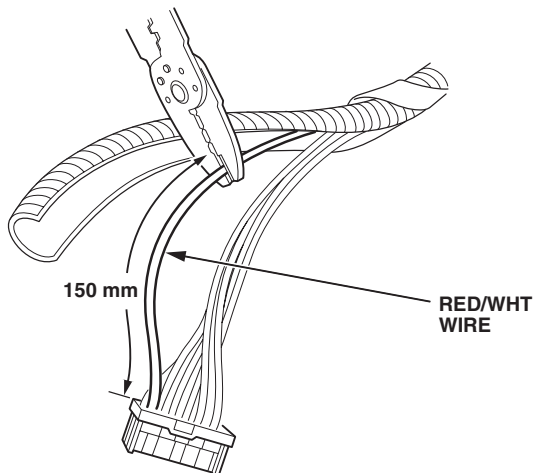

11. Inspect the 16P connector for heat damage or discoloration.
  - If the connector is OK, go to step 12.
  - If the connector is damaged or discolored, go to step 14.
12. Using the Secondary Lock Opener from the Terminal Maintenance Set (T/N 070AZ-S5A0100), carefully pry open the secondary lock on the RED/WHT wire side of the 16P connector.

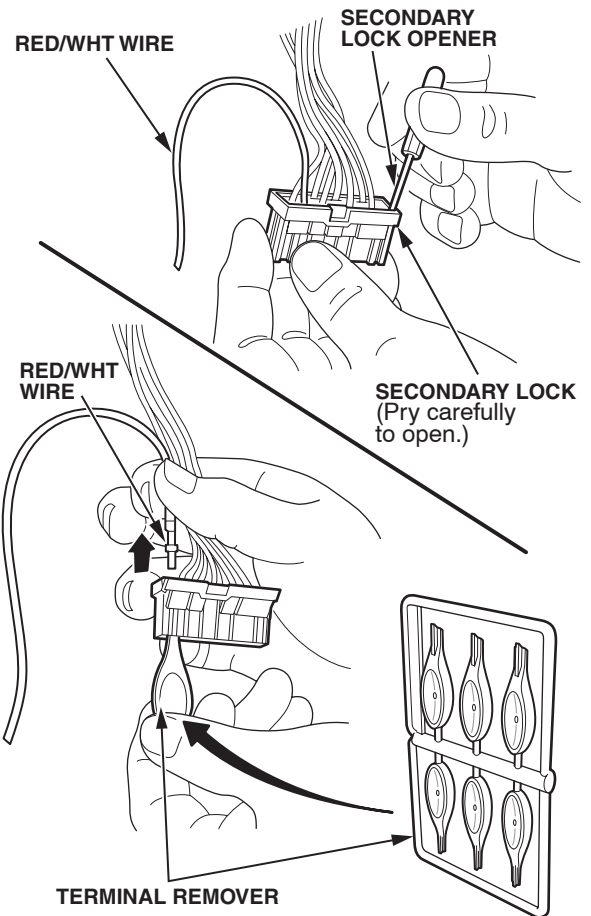

13. Twist off a terminal remover from the Terminal Remover Set (T/N 070AZ-S5A-011). Insert the terminal remover into the center row cavity of the 16P connector, above the RED/WHT wire cavity, then remove and discard the RED/WHT wire.

14. Strip off 7 mm of insulation from the vehicle wire harness side of the RED/WHT wire. Insert the stripped end into one side of the splice connector, and crimp the connector.

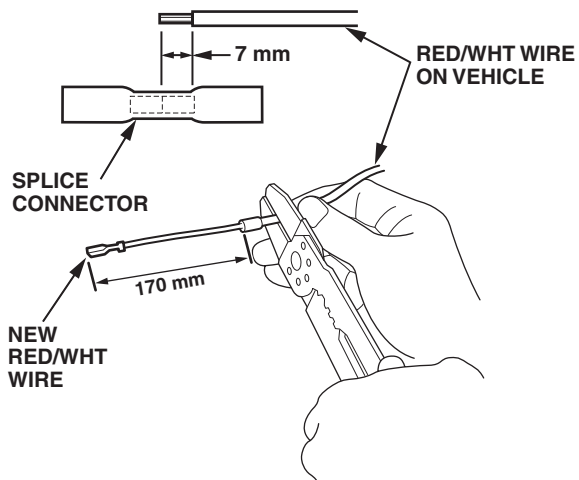

15. Cut the new RED/WHT wire 170 mm from the end of its terminal. Then strip off 7 mm of insulation from the cut end.
16. Insert the stripped end of the new RED/WHT wire into the other side of the splice connector, then crimp the connector.
17. With a non-combustible material between the RED/WHT wire and the vehicle wire harness, use a heat gun to shrink the splice connector casing.

**NOTE:**

- Be careful not to get burned.
- Do not overheat the wire.

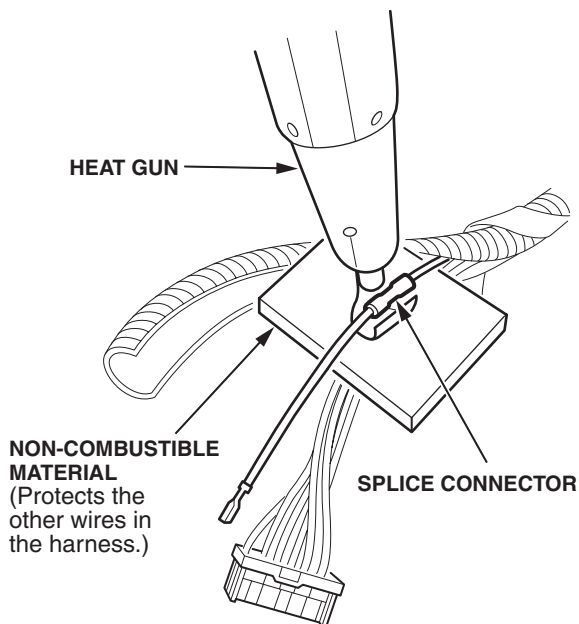

18. If the original 16P connector is not heat damaged or discolored, insert the new RED/WHT wire into its proper terminal cavity on the connector, then go to step 22. If the 16P connector is damaged, go to step 19.
19. Using the secondary lock opener from the Terminal Maintenance Set (T/N 070AZ-S5A-010), carefully pry open the other secondary lock on the 16P connector.
20. Twist off a terminal remover from the Terminal Remover Set (T/N 070AZ-S5A-011). Insert the terminal remover into a center row cavity of the original 16P connector, remove the corresponding wire from its cavity, and transfer it to the same cavity in the new 16P connector. Repeat this for all the wires except the original RED/WHT wire.

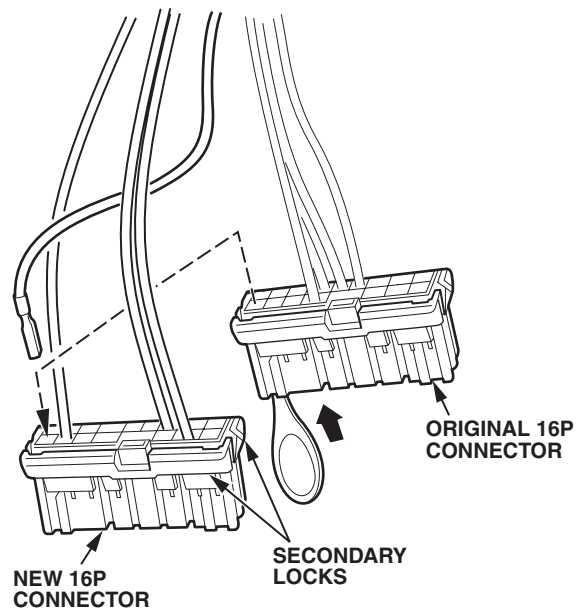

21. Insert the new RED/WHT wire into its proper terminal cavity in the new 16P connector.
22. Snap the secondary lock(s) closed on the 16P connector.
23. Using electrical tape, retape the wire harness or insert the wires into the corrugated tubing/foam and retape the tubing/foam.
24. Install the new combination light switch with the two original screws.
25. *On Civics*, reroute the wire harness over the steering column, then connect the 16P connector to the combination light switch, the 5P connector to the cable reel connector and, *on Civic Hatchbacks*, the 14P connector to the wiper switch. *On Insights*, connect the 16P connector to the combination light switch.
26. Connect the negative cable to the battery.
27. Check the operation of the headlights, the parking lights, and the turn signals.

28. On Civics, install the driver's dashboard lower cover.
29. Install the steering column covers.
30. Enter the radio anti-theft code (if applicable), then enter your customer's radio station presets. Set the clock.
31. Do the idle learn procedure:
  - Make sure all electrical items (A/C, audio unit, lights, etc.) are off, then start the engine.
  - Let the engine reach normal operating temperature (the cooling fans cycle twice).
  - Let the engine idle (throttle fully closed) for 10 minutes.
32. On 2001 Civic LX and EX 2-door models thru VIN 1HGEM2...1L016502, do the cruise control learn procedure:
  - Drive the vehicle, and set the cruise control above 40 miles per hour.
  - Drive the vehicle for 5 to 10 minutes at the set speed. If you cancel the set speed before driving 5 to 10 minutes, repeat the procedure.

NOTE: This procedure can also be done on a chassis dynamometer, but it cannot be done with the vehicle on a lift.
33. Center-punch a completion mark above the 12th character of the engine compartment VIN.

Center-punch here.

**1HGXXXXXXXXXXXXXX**

*Example of Customer Letter*

Spring 2004

### Safety Recall Campaign: Headlight Switch

Dear Honda Owner:

This notice is sent to you in accordance with the requirements of the National Traffic and Motor Vehicle Safety Act.

#### What is the reason for this notice?

Honda Motor Co., Ltd., has decided that a defect relating to motor vehicle safety exists in certain 2001–02 Civics and 2000–01 Insights. A terminal in the headlight wire harness can overheat and may cause the low-beams to fail without warning. Although the high-beam position remains operational, an unexpected loss of low beams could result in a crash.

#### What should you do?

Call any authorized Honda dealer and make an appointment to have your vehicle repaired. The dealer will inspect the headlight switch and replace all needed parts. This work will be done *free of charge*. Please plan to leave your vehicle for half a day to allow the dealer flexibility in scheduling.

#### Who to contact if you experience problems.

If you are not satisfied with the service you receive from your Honda dealer, you may write to:

American Honda Motor Co., Inc.  
 Honda Automobile Customer Service  
 Mail Stop 500-2N-7A  
 1919 Torrance Blvd.  
 Torrance, CA 90501-2746

If you believe that American Honda or the dealer has failed or is unable to remedy the defect in your vehicle, without charge, within a reasonable period of time (60 days from the date you first contact the dealer for a repair appointment), you may submit a complaint to:

Administrator  
 National Highway Traffic Safety Administration  
 400 Seventh Street, SW  
 Washington, DC 20590

Or call the toll-free Safety Hotline at (888) 327-4236.

#### What to do if you feel this notice is in error.

Our records show that you are the current owner or lessee of a 2001–02 Civic or 2000–01 Insight involved in this campaign. If this is not the case, or the name/address information is not correct, please fill out and return the enclosed, postage-paid *Information Change Card*. We will then update our records.

If you already paid to have a defective headlight switch replaced, you may be eligible for reimbursement. Refer to the attached instructions for eligibility requirements and the reimbursement procedure.

#### Lessor Information.

Federal law requires that any vehicle lessor receiving this recall notice must forward a copy of this notice to the lessee within 10 days.

#### If you have questions.

If you have any questions about this notice, or need assistance with contacting a Honda dealer, please call Honda Automobile Customer Service at (800) 999-1009, and select menu option #2.

We apologize for any inconvenience this campaign may cause you.

Sincerely,

**American Honda Motor Co., Inc.  
 Honda Automobile Division**